

# ALKAR Multi-Product

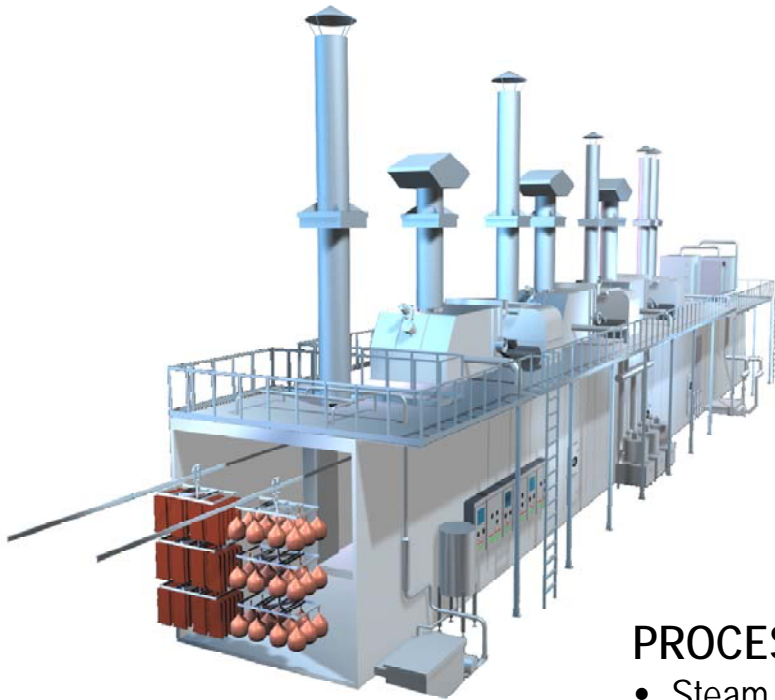

## PROCESS FLEXIBILITY

- Steam, water, or dry cook
- Natural or liquid smoke
- Brine, water, or air chill
- Independent conveyor speed control
- Process different products in each lane

## PROVEN WALKING BEAM CONVEYOR SYSTEM

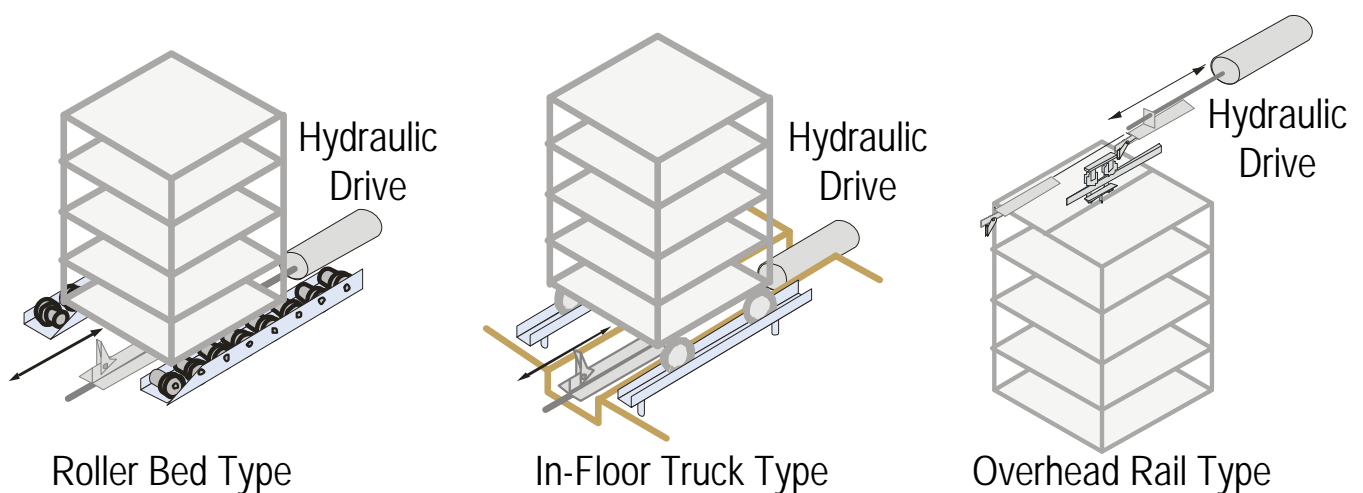

- Durable design for high density/heavy loading to maximize capacity
- Stainless-steel conveyor and hydraulic drive system

# ALKAR Multi-Product

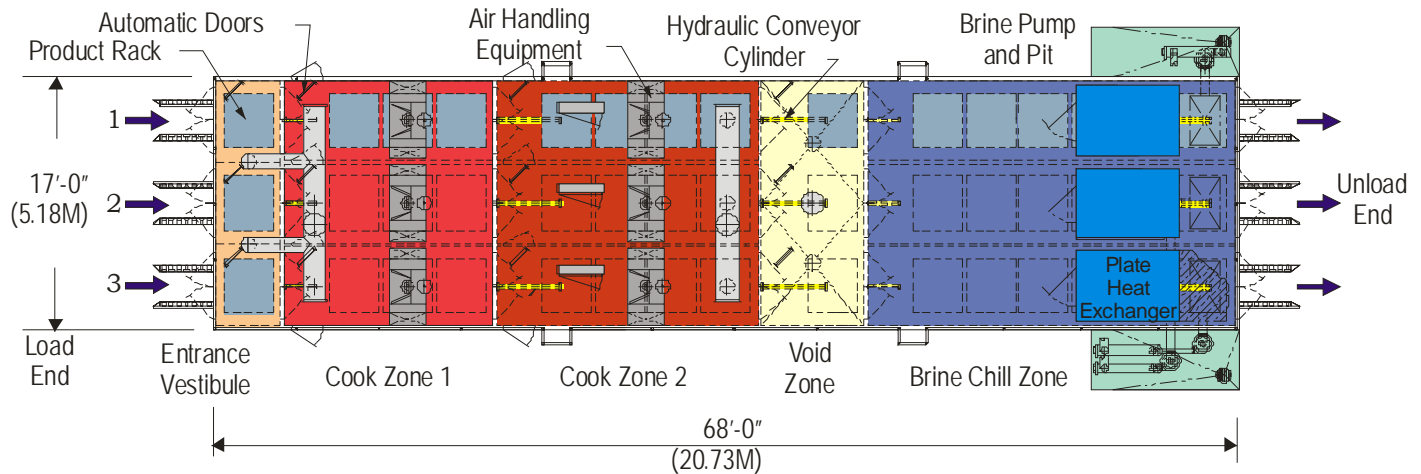

8,800 lbs/hr (3992 kg/hr) Bologna System

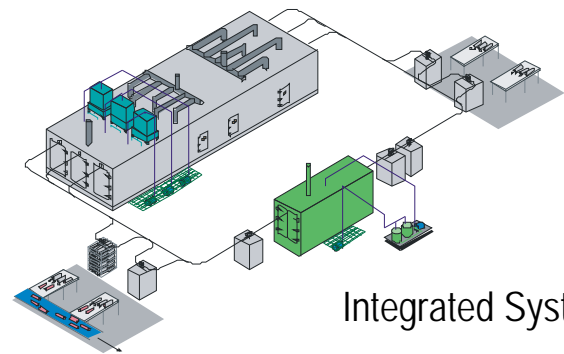

10,260 lbs/hr (4664 kg/hr) Bacon Processing System

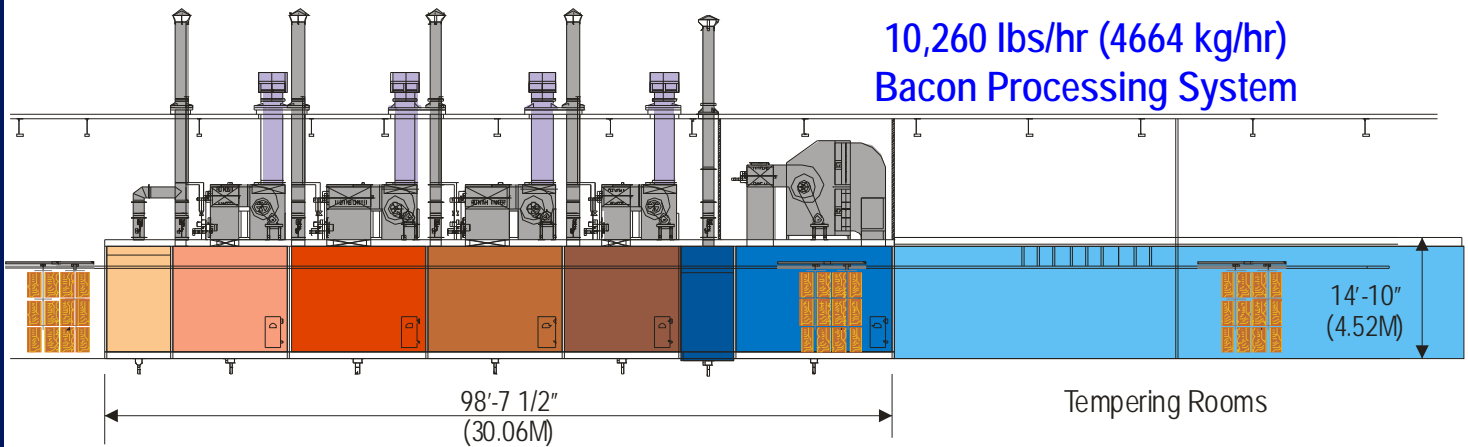

## PROCESS CONTROL

- Programmable temperature, % relative humidity and conveyor control
- Automatic doors isolate zones
- Superior air handling ensures uniformity
- Staging conveyors at load / unload areas