

## DEFROST SYSTEM

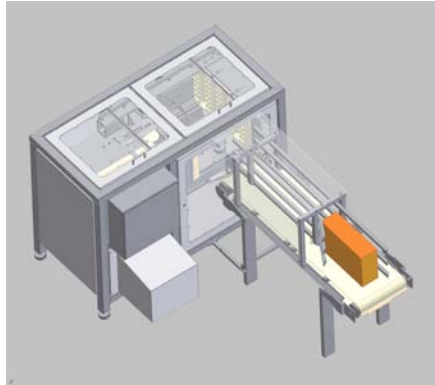

1. The operator unwraps a frozen meat block and places it on the conveyor

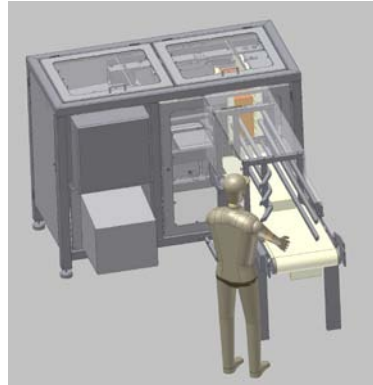

2. The frozen block enters the inlet of the meat block divider

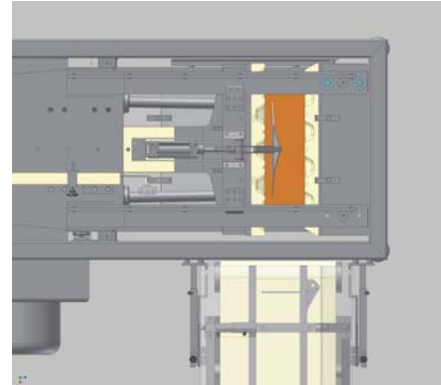

3. The frozen block is pressed once, rotated 90° and pressed again to break up the individual muscles for defrosting process

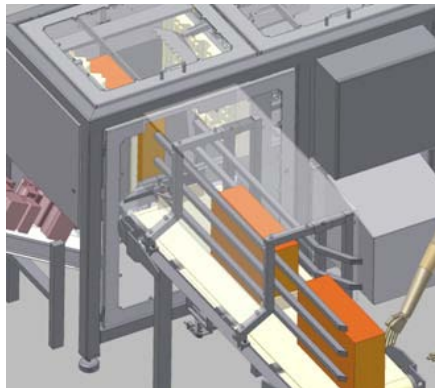

4. Separated frozen muscle pieces from the fragmented blocks discharge to a conveyor below.



5. The frozen pieces are transported to the tumbler or group of tumblers for defrosting.

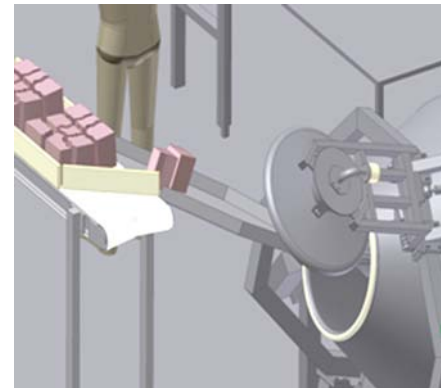

6. A chute loads each tumbler with pre-broken, frozen product for tumbling.

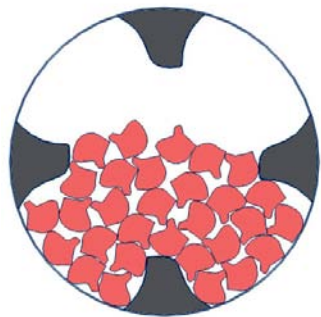

7. Careful, indirect temperature control inside the tumbler thaws the whole muscle pieces. Product is cooled inside the tumbler once it is defrosted.

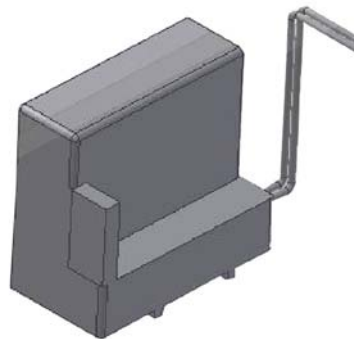

8. The heating unit consists of a tube & pumping system. The cooling unit consists of two compressors, tube & pumping system, and a buffer tank.

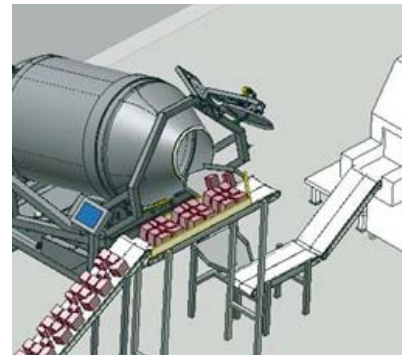

9. Defrosted product discharges from the tumbler onto a conveyor for tenderizing, injection, or further processing.

## DEFROST SYSTEM

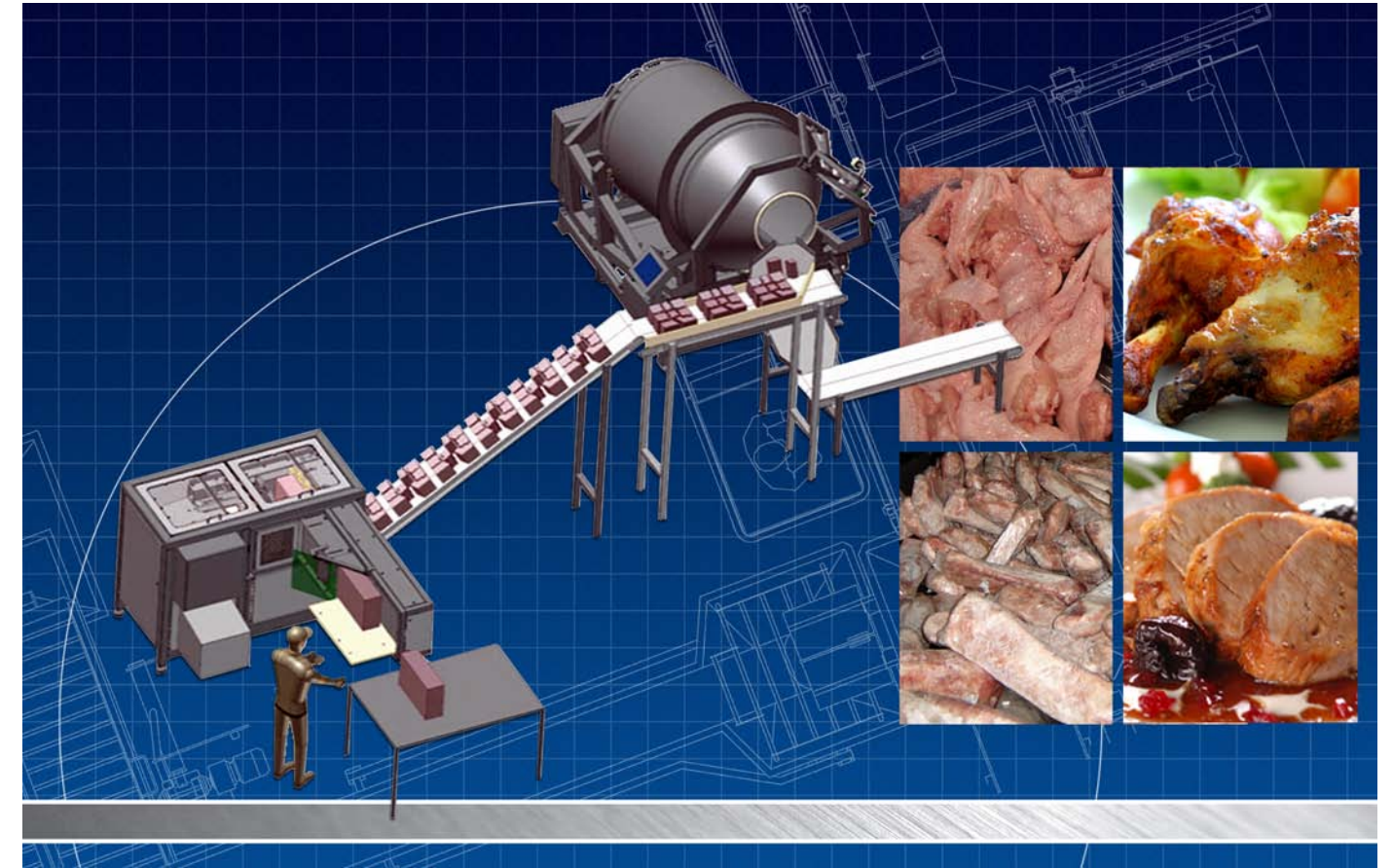

**Contoured wing design allows for hard or gentle tumbling action during defrost with optimal flow conditions for ideal energy transfer (heat or cold).**

## DEFROST SYSTEM

- Separate frozen meat blocks without damage to whole muscle fibers and membranes.
- Process suitable for poultry, beef, pork, and fish to preserve natural meat qualities.
- Optimized processing time without dripping or protein loss during thawing.
- Thawing in the tumbler unit controlled through indirect temperature heating through specially designed wings while product tumbles inside.
- Modular design enables separator to load multiple tumblers for larger volume utilization.
- PanelView controls for user-friendly interface.
- Built in conformity with AMI sanitary equipment design principles. USDA accepted and CE approved.



# Can You Afford to Use Any Other Defrosting System?

Danfotech offers a cleaner, more efficient way to defrost frozen blocks with an innovative system that minimizes labor and space. The modular design makes the defrosting system expandable to meet your production requirements.

Until now, defrosting frozen meat blocks involved exposing the product to running water, hot air, steam or microwave tunnels and the results were far from perfect. Compared to traditional defrosting systems methods, the Danfotech Defrost system gives you an additional finished product instead of loss caused by dripping or overheating of the product. The result is a natural-looking defrosted product attained with this revolutionary controlled heating and cooling process.

Frozen blocks in the 0° to 10° F (-18° to -12° C) temperature range, depending on product, are placed on a conveyor and pass through a meat block divider. The blocks are pressed and separated into individual muscles without damaging the fibers or membranes. This results in more consistent batches in terms of temperature and appearance. The separated blocks discharge onto a conveyor that transports them to tumblers for defrosting. After defrosting, the product can be directly transferred for tenderizing, injecting or other further processing.

## Danfotech Defrosting System Advantages

Traditional Defrosting Methods:	Danfotech's Defrost System:
<ul style="list-style-type: none"> <li>Flavor, salt and protein drip loss of 5% to 8%.</li> <li>Space-consuming process</li> <li>Difficult to control surface temperature and bacteria count</li> <li>Processing time of 24 to 48 hours or longer</li> </ul>	<ul style="list-style-type: none"> <li>Separation of meat block by meat press</li> <li>Variable temperature control - heat &amp; cool</li> <li>Speed control</li> <li>Hard or soft tumbled product depending on rotation direction</li> <li>Transfer to injection or further processing</li> <li>A controlled process with less handling and space requirements</li> <li>50% to 55% fill degree reduces requirement for additional tumbler investment/capacity.</li> <li>No chipped product, purge or drip loss</li> <li>Controlled surface temperature</li> <li>Processing times of up to 3 batches per 24 hours, including sanitation.</li> <li>Better production economy with shorter process time after defrost</li> <li>Higher bacteriological standard</li> <li>Tight temperature control through critical 25°-32° F (-4° to 0° C) zone</li> <li>No ice crystal formation or warm surfaces</li> <li>Brine returns juice to meat by massaging</li> </ul>
<b>Defrost in vats with running water</b> <ul style="list-style-type: none"> <li>Product picks up water, dilutes proteins</li> <li>High bacterial growth rate</li> <li>Purge / protein loss</li> <li>Wastewater issues</li> </ul>	
<b>Defrost cabinets utilizing hot air</b> <ul style="list-style-type: none"> <li>High bacterial growth rate</li> <li>Purge / protein loss</li> <li>Meat surface dry and discolored</li> </ul>	
<b>Microwave tunnels with RF waves</b> <ul style="list-style-type: none"> <li>Hot spots and denatured protein</li> <li>Inability to bind</li> <li>Purge / protein loss</li> <li>High energy cost</li> </ul>	
<b>Steam injection into tumbler</b> <ul style="list-style-type: none"> <li>Adds undesirable moisture from boiler</li> <li>May damage surface of the meat</li> <li>Non-separated meat blocks only allow 30 to 35% filling of tumbler.</li> </ul>	

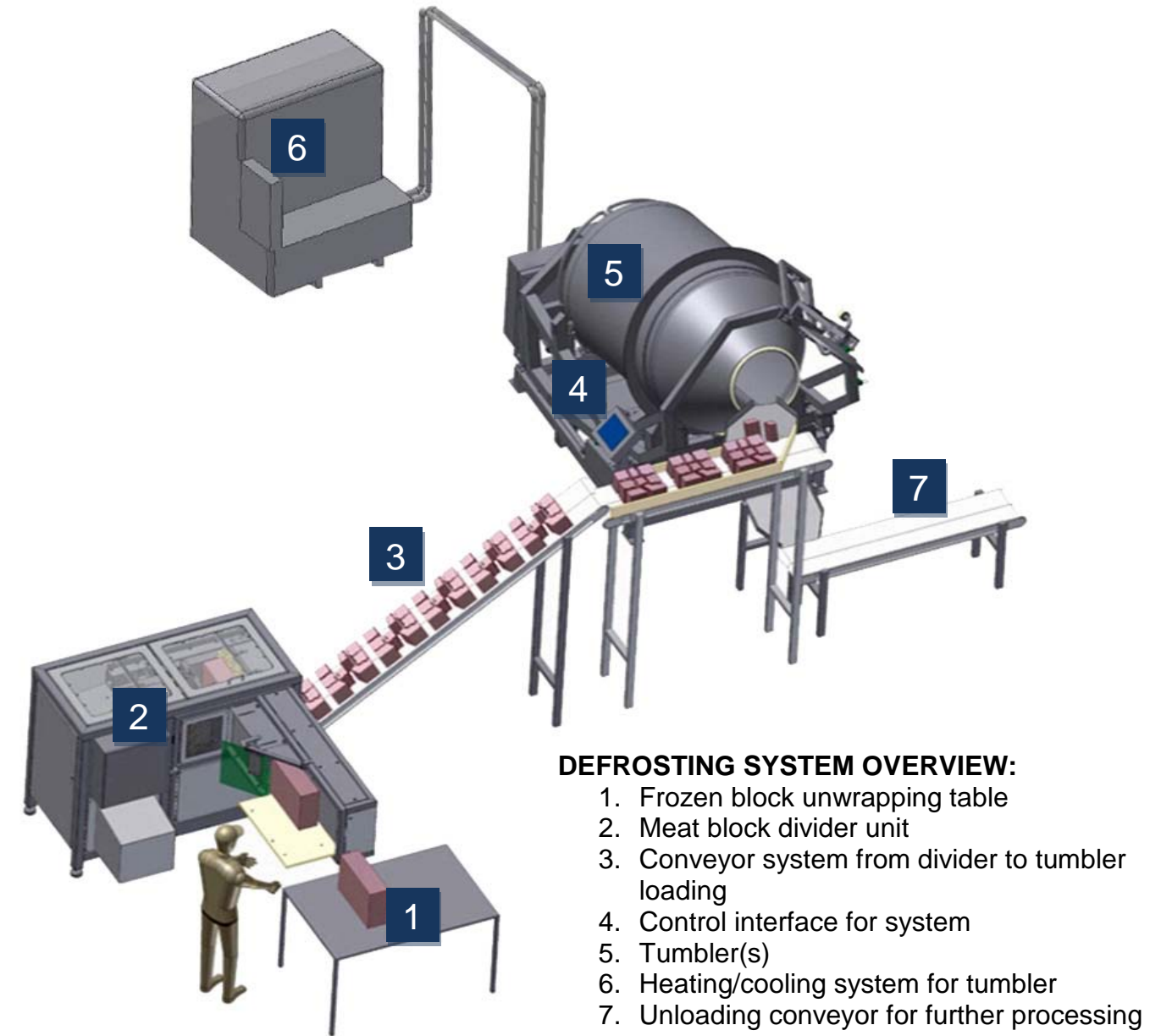

- DEFROSTING SYSTEM OVERVIEW:**
1. Frozen block unwrapping table
  2. Meat block divider unit
  3. Conveyor system from divider to tumbler loading
  4. Control interface for system
  5. Tumbler(s)
  6. Heating/cooling system for tumbler
  7. Unloading conveyor for further processing

## Defrosting System Comparisons

Method	Traditional Defrosting System	Danfotech System
<b>Time</b>	Water treatment 12-18 hours Heating: 12-18 hours Equalizing room: 2-3 days at 50°-59° F	Up to 3 batches in 24 hours, including loading, unloading and cleaning (varies by product)
<b>Product Loss</b>	8% direct loss, cannot be restored by additives or ingredients	1% loss or less, brine returns juice to meat during massaging tumbling, no chipping or purge loss
<b>Bacterial Growth</b>	Longer processing time and higher temperatures on meat surface increase and accelerate bacterial growth on products.	Shorter processing times and a temperature-controlled process ensure a more perfect product for further processing
<b>Labor</b>	Unpack products on pallets or racks. Considerable material handling of frozen and thawed product.	Products unpacked and placed on conveyor. Defrosting process loads and unloads automatically to reduce labor.
<b>Sanitation</b>	Manual cleaning of racks, pallets, etc.	Clean-in-place tumbler, partially automated cleaning

