

SERVO BACON PRESS

- Presses up to 20 bellies per minute depending on size, the consistency of belly conditions and uniform loading of the infeed belt.
- Servo actuators throughout. **No hydraulics** for maximized speed and precision control. Smooth operation from optimized motion control prolongs part life and reduces maintenance costs. **No hydraulic cooling water needed.**
- Computer controlled die set allowing ± 0.22 " (5.5 mm) adjustment for product thickness during operation without physically changing the die set.
- Maximize slicing yields at optimal temperatures ranging from 14°-25° F (-10° to -4° C) depending on salt content.
- External bushings for easy maintenance.
- Change die sets in 5 minutes without any tools.
- Allen-Bradley controls with 12" color touch screen HMI. Intuitive program with extensive diagnostics. Internet connectivity for remote troubleshooting. Remotely mounted electrical panel out of production area.
- USDA accepted and CE approved. Built in conformity with AMI sanitary equipment design principles.

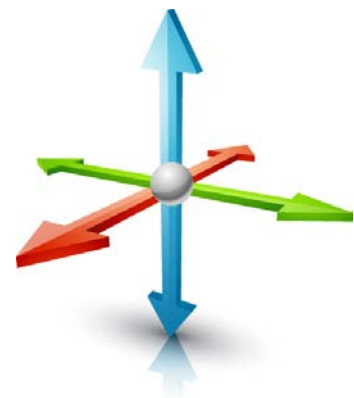

High Speed 3-Axis Servo Pressing

Featuring the industry's
largest product chamber

SERVO BACON PRESS

The All-Servo Actuator Driven Press presses bellies by means of a die set, in shapes that correspond to the desired finished product.

The frozen meat is molded in the servo controlled press, where it is exposed to three-dimensional pressure from four directions to attain uniform shape and quality for maximized slicing yields. The pressed length is attained with pressure applied from both ends simultaneously. The pressing method ensures that no membranes are damaged, resulting in extra slices. Press cycle establishes product height and width. Pressed length depends on the size of a belly.

The servo bacon press has a maximum die chamber size of 38" x 16" x 4.8" (965 x 406 x 122 mm). It also includes autoloading infeed with discharge conveyor. Additional ancillary systems are available.

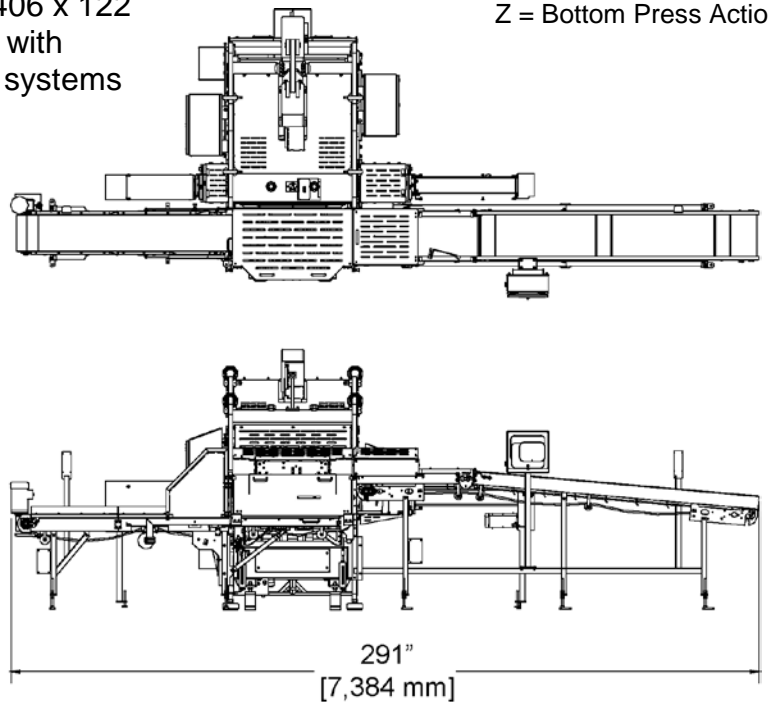
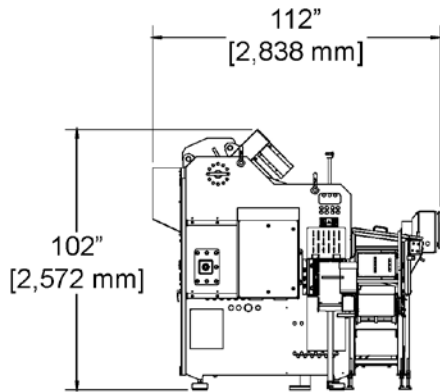
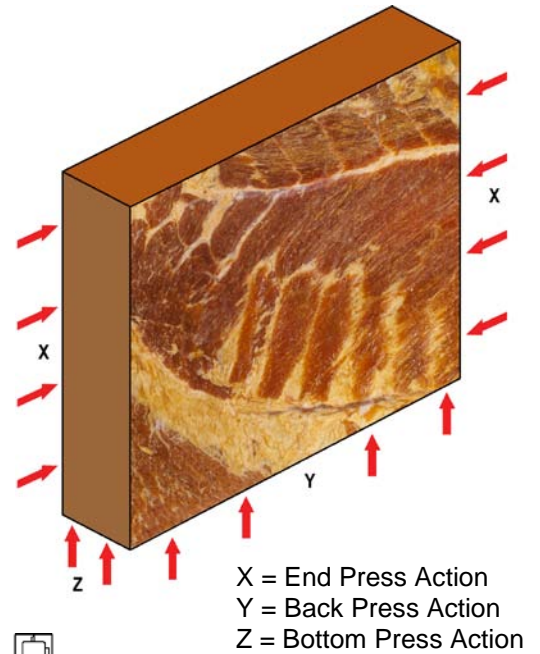

SPECIFICATIONS			
Power	Control Voltage	Service Amps	Air Pressure
460 VAC/60 Hz	24 VDC	100 A	90 psi 6 bars

05/14 E

THE MIDDLEBY CORPORATION
PROCESSING & PACKAGING TECHNOLOGY BRANDS

www.danfotech.com • sales@danfotech.com

DANFOTECH

United States:
4300 W. Bryn Mawr Avenue
Chicago, IL 60646-5943
773 478-9700

Brazil:
Rua Antonio das Chagas, 439
Chacara Santo Antonio
CEP: 04714-000
Sao Paulo, SP
+55-11-3321-5858

Denmark:
Indkildevej 12F
DK-9210 Aalborg SØ
+45 98 16 55 00

Italy:
Via Dei Carpini, 5/7
Z.I. Fenilrosso
46019 Viadana, (MN)
+39-(0)-375-781-797

Mexico:
Ave. Avante No. 840
Parque Ind. Guadalupe
Guadalupe, N.L. 67190
+52-81-8262-6000