



ProfitLine

The industrial system for smoking fish

Advantages

Wide variety of flavours and colours:

All external and various internal smoke generation systems, such as smouldering smoke, condensate smoke or friction smoke, are available for smoking fish.

Efficiency:

Extensive air circulation guarantees constant product quality with minimum weight loss upon drying and smoking despite maximum trolley loading.

Designed for industry:

- Wide door opening clearance

Environmentally friendly:

The system can be used with friction smoke generator without any additional subsequent cleaning equipment.

Characteristics

Use:

The systems are universal allrounders thanks to their horizontal and vertical air circulation, whether fish is placed horizontally on mesh shelves or suspended on spits.

Possible processes:

- drying
- hot and cold smoking

Air systems:

- Direct drive with frequency converter
- Central air handling unit
(very high air speed air in contact with the products)

Hygiene:

- Segment construction
- Automatic interior cleaning

ProfitLine: The industrial system for smoking fish

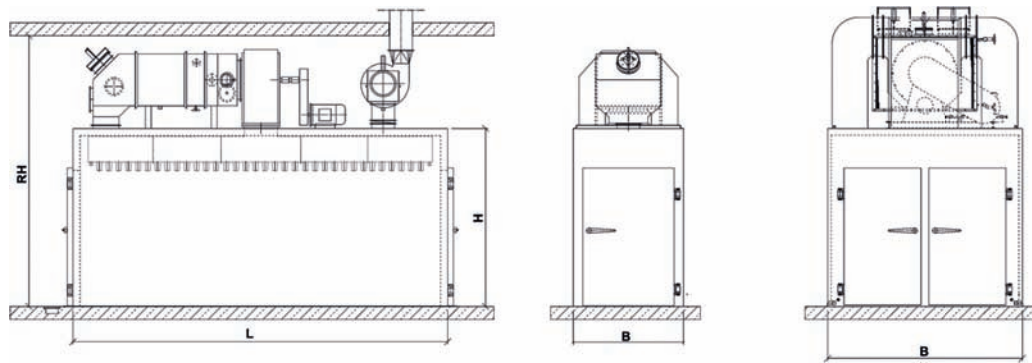

	PFR type	Number of trolleys	Door opening clearance (cm)		Cabinet dimensions (incl. extension) (cm)			Min. room height (cm)	Electric kW [⊙]	Heating Steam kW [⊙]	Heating Electric kW [⊙]	Heating Oil; Gas kW [⊙]	Cooling system Cold smoke from-to kg/h [⊙]	Low pressure steam/Water Cooking l/min [⊙]	Water Shower kg	Weight kg
			width	height	height [H]	width [B]	length [L] [⊙]									
Tandem	1043	4	120	210	275	170	473	400	17,2	140	116	160	20-40	184	50	3200
	1053	5	120	210	275	170	584	450	23,2	174	145	200	25-50	230	65	3700
	1063	6	120	210	275	170	695	450	25,2	209	175	240	30-60	276	75	4200
	1073	7	120	210	275	170	806	480	31,5	244	203	280	35-70	322	85	4700
	1083	8	120	210	275	170	917	480	35,5	279	232	320	40-80	368	100	5200
Parallel	2063	6	(2x) 120	210	275	300	362	450	25,2	209	175	240	30-60	276	75	3800
	2083	8	(2x) 120	210	275	300	473	480	35,5	279	233	320	40-80	368	100	4600
	2103	10	(2x) 120	210	275	300	584	500	44,5	349	291	400	50-100	460	125	5400
	2123	12	(2x) 120	210	275	300	695	500	55,5	419	349	480	60-120	552	150	6200
also to be considered			wedge (2x for tunnel)				plus 15									
			without tunnel				plus 8,5									
			overhead rail	on request				on request								
			lifting doors					min. 500								
			aggregate at rear/ at side	possible/ [RH]re duced to			350-400									

⊙ with tunnel

⊙ approximately connected loads

* aggregate on top

Features	Description	Standard	Options	Further flyers
Operation	external operating controls	x		Control and documentation systems
Standard heating (optional)	electric (160 °C)	x		
	low pressure (80 °C)	x		
	high pressure (120 °C)	x		
Smoke	gas (160 °C)	x		
	external smoke generator		x	External smoke generators
	internal smoke generator		x	Internal smoke generators
	RONDAIR exhaust reduction system		x	
Cleaning	exhaust air cleaning		x	Environment and energy efficiency systems
	interior cleaning	x		
Exhaust air system	cleaning equipment		x	Cleaning systems
Exhaust air system	exhaust air fans	x		
Cold smoke	cooling system		x	
Horizontal air flow	horizontal air circulation system		up to 1063	
Floor	double-walled, without slope	x		
	anti-slide profile		x	
Doors	lifting door hinge, lifting 15mm	x		
Tunnel design	additional doors on the unloading side		x	
	interlocking		x	
Lifting doors	instead of swing doors		x	
Transport systems	floor transport (automatic)		x	Semi-continuous unit systems
	overhead rail (automatic)		x	Semi-continuous unit systems
	overhead rail with max. 1t/cart place (man.)		x	