

MPADVANTAGE™ Drum Breader

MPADVANTAGE™ DRUM BREADERS ARE DESIGNED TO ACCURATELY HANDLE FLOUR BREADING AND REDUCE DOWNTIME AND WASTE

- All stainless steel drum provides unmatched durability and maximum production capability
- Construction is all stainless steel frame with US standard fasteners, bearings, sprockets, belting and shafts with sanitary open frame design
- Heavy-duty drum drive support system provides positive drum drive without slipping
- Exclusive MP direct auger transfer system helps eliminate breading jamming and provides efficient transfer with less breading in machine
- Extended vertical screw housing provides more efficient breading transfer into drum without vibrators
- Includes automatic "crumb" removal system and allows precise removal of moist crumbs from flour
- Standard right hand controls, option for left hand
- One piece aluminum hydraulic manifold with stainless steel hydraulic flow control valves provides precise motor speed control
- Durable, non-rusting valves
- 10-60 FPM variable speed hydraulic drives with plated motors

- Quick disconnect couplings for easy motor change out
- Separate variable speed direct drive augers eliminates chains, sprockets and gear boxes and provides precise individual speed control
- MP Exclusive "gull wing" door system

- with lift cylinders allows complete access to machine for sanitation and maintenance
- Hood provides fully enclosed drum and drive system and reduces airborne dust
- 150 lb. breading capacity feeder with variable speed hydraulic drive allows consistent addition of breading blending new breading with return for even application to product
- Low profile 30" hopper feed height allows operators to load machine ergonomically at floor level to avoid climbing steps or lifting heavy bags of breading overhead. Meets Canadian ergonomic regulations
- Self-contained hopper unit rolls on supplied casters



MPADVANTAGE™ Drum Breader with low profile hopper



MPADVANTAGE™ Drum Breader- right-side view

MPADVANTAGE™ Drum Breeder

Technical Information

MACHINE DIMENSIONS

Machine	A	B	C	D	E	
Standard	95.5"	1-55" doors closed 2-75.25" doors open	198.75"	1-29.25" 2-21.5"	43.625"	Infeed Transfer Height: 41.75" Discharge Transfer Height: 38"

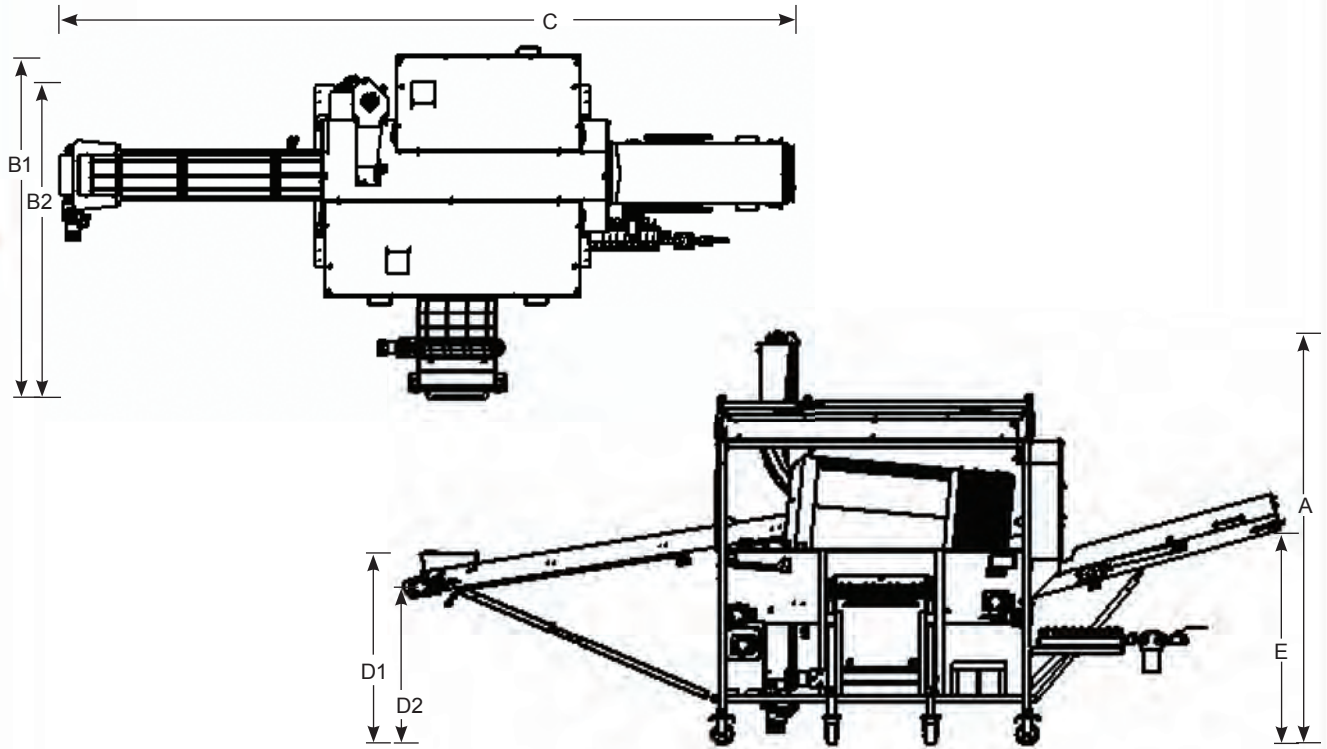

UTILITIES

Model	Standard		
Breeder Capacity:			
Flour	minimum lbs.		100
	maximum lbs.		200
Hydraulic Drive: (900 PSI max) at 40 FPM. Range: 10-60 FPM.			
Main Belt	GPM		2.5
	RPM		78.5
Vertical Screw	GPM		7.3
	RPM		232.3
Feed Screw	GPM		4.7
	RPM		157.6
Infeed Belt	GPM		1
	RPM		37.7
Discharge Belt	GPM		1
	RPM		37.7
Drum Drive*	GPM		8
	RPM		151

*uses two motors in series, each using 4 GPM at 151 RPM 800 PSI

- SERVICES OFFERED -

- 24/7 Service
- Spare Parts Department
- Application Support
- Technical Support
- Line Audits

- MP WARRANTY POLICY -

MP Equipment will repair or replace any MP manufactured component that fails due to defect in material or workmanship within **24 months** from shipment.

All OEM parts covered by individual warranties.

MP EQUIPMENT COMPANY

Your Best Value for Processing Solutions



Specifications subject to change