

MPADVANTAGE™ Inline Breader

OUR HEAVY-DUTY BREADERS ARE DESIGNED AND MANUFACTURED FOR MAXIMUM OPERATING EFFICIENCY AND RELIABILITY WITH SAFETY AND ERGONOMIC FEATURES

- Construction is all stainless steel with US Standard bearings, belting and shafts. Direct feed 9" vertical screw with bottom direct drive. 3/8" .082 wire belting or 1/2" pitch to optimize product handling
- Flour coating configuration, option for "J" crumbs
- Inline discharge
- Excess breading removal set up with two blow-off tubes above product zone for tie into plant central blower system
- Discharge breading sifter system
- Stainless steel hard piped hydraulic system with one piece aluminum hydraulic manifold
- MP rotating top flow breading distribution system
- Standard tie bar connections

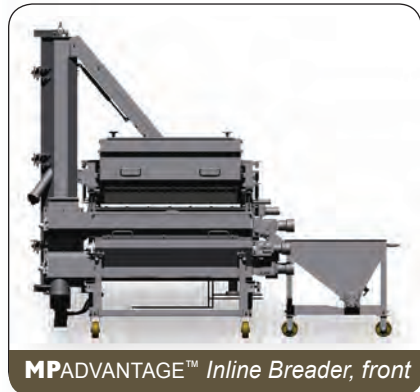

MPADVANTAGE™ Inline Breader, front

- Standard casters with stainless steel frame and Phenolic Wheels
- Rotating belt vibrator
- 150 lb. breading capacity feeder with variable speed hydraulic drive allows consistent addition of breading blending new breading with return for even application to product
- Low profile 30" hopper feed height allows operators to load machine



MPADVANTAGE™ Inline Breader, Patent Pending



adjustable support for batter applicator discharge



paddle transfer from cross feed to vertical auger

- ergonomically at floor level to avoid climbing steps or lifting heavy bags of breading overhead. Meets Canadian ergonomic regulations
- Self-contained hopper unit rolls on supplied casters
- Positive cam/lock on all access doors
- Lift cylinder on discharge chute, hopper and covers
- Adjustment/support for discharge of

- batter applicator
- Belt tension adjustment for hopper/main belt
- Stand-off bearings for maximum sanitary design
- Hydraulic lines hard piped
- Engineered for safety, user friendliness and optimum uptime
- Flexible breader design for heavy production of flour, free flow and Japanese crumb coatings
- Operator controls ergonomically designed
- Designed for 34", 40" and 52" usable belt width

MPADVANTAGE™ Inline Breeder

Technical Information

MACHINE DIMENSIONS

Machine	A	B (+6")	C (w/side feed hopper)	Infeed Transfer:
52" Breeder	118.5"	94.5"	112.3"	39"-45"
40" Breeder	118.5"	94.5"	100.5"	Discharge Transfer:
34" Breeder	118.5"	94.5"	94.5"	39"-45"

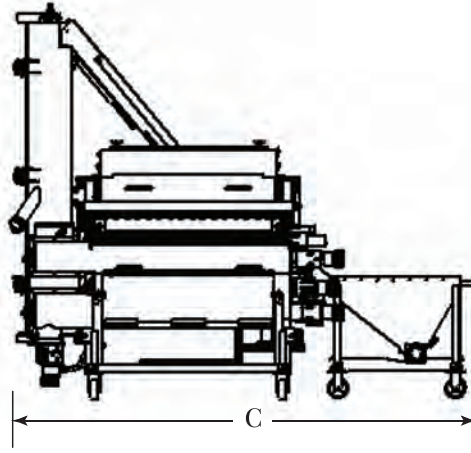
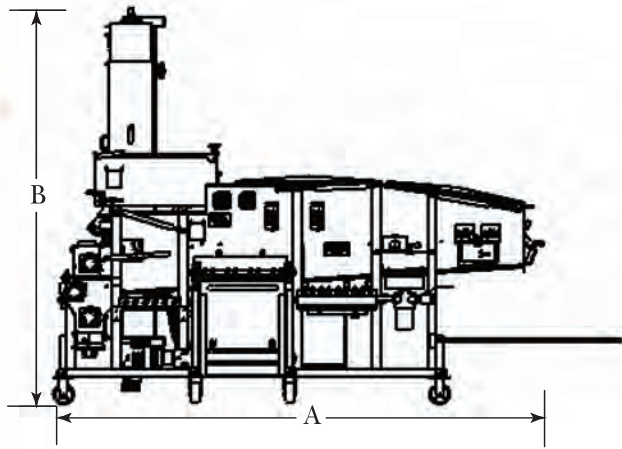

UTILITIES

Model		34	40	52
Breeder Capacity:				
Free Flowing	minimum lbs.	200	250	350
	maximum lbs.	350	400	500
Flour	minimum lbs.	200	250	350
	maximum lbs.	350	400	500
Hydraulic Drive: @ 60 FPM. Range 10-60 FPM				
Main Belt	GPM	2.0	2.0	2.0
	RPM	160	160	160
Vertical Screw	GPM	10.0	10.0	10.0
	RPM	400	400	400
Bottom Layer Screw	GPM	7.6	7.6	8.0
	RPM	300	300	350
Top Hopper	GPM	1.1	1.1	1.1
	RPM	200	200	200
Filter Conveyor	GPM	2.0	2.0	2.0
	RPM	95	95	95
Feed Screw	GPM	7.6	7.6	7.6
	RPM	300	300	350
Spreader Wheel	GPM	1.4	1.4	1.4
	RPM	55	55	55
Belt Vibrator	GPM	2.1	2.1	2.1
	RPM	390	390	390
Side Feed Hopper (optional)	GPM	1.2	1.2	1.2
	RPM	10	10	10

Specifications subject to change

- SERVICES OFFERED -

- 24/7 Service
- Spare Parts Department
- Application Support
- Technical Support
- Line Audits

- MP WARRANTY POLICY -

MP Equipment will repair or replace any MP manufactured component that fails due to defect in material or workmanship within **24 months** from shipment.

All OEM parts covered by individual warranties.

MP EQUIPMENT COMPANY
Your Best Value for Processing Solutions

